

Part Number: PT278-35075  
PT278-00160

**Kit Contents**

Item #	Quantity Req.	Description
1	1	Mini Tie-Downs (2-pack)
2		
3		

**Hardware Bag Contents**

Item #	Quantity Req.	Description
1		
2		
3		

**Additional Items Required For Installation**

Item #	Quantity Req.	Description
1		
2		
3		

**Conflicts**

Tonneau Cover
---------------

**Recommended Tools**

Personal & Vehicle Protection	Notes
Special Tools	Notes
Installation Tools	Notes
Special Chemicals	Notes

**General Applicability**

All Models
------------

**Recommended Sequence of Application**

Item #	Accessory
1	
2	
3	

\*Mandatory

**Vehicle Service Parts** (may be required for reassembly)

Item #	Quantity Req.	Description
1		
2		
3		

**Legend**

 **STOP:** Damage to the vehicle may occur. Do not proceed until process has been complied with.

 **OPERATOR SAFETY:** Use caution to avoid risk of injury.

 **CAUTION:** A process that must be carefully observed in order to reduce the risk of damage to the accessory/vehicle and to ensure a quality installation.

 **TOOLS & EQUIPMENT:** Used in Figures calls out the specific tools and equipment recommended for this process.

 **REVISION MARK:** This mark highlights a change in installation with respect to previous issue.

 **SAFETY TORQUE:** This mark indicates that torque is related to safety.



Care must be taken when installing this accessory to ensure damage does not occur to the vehicle. The installation of this accessory should follow approved guidelines to ensure a quality installation.

These guidelines can be found in the "Accessory Installation Practices" document.

This document covers such items as:-

- Vehicle Protection (use of covers and blankets, cleaning chemicals, etc.).
- Safety (eye protection, rechecking torque procedure, etc.).
- Vehicle Disassembly/Reassembly (panel removal, part storage, etc.).
- Electrical Component Disassembly/Reassembly (battery disconnection, connector removal, etc.).

Please see your Toyota dealer for a copy of this document.

**1. Install the Mini Tie-Downs.**

**STOP** **CAUTION: Do not install Mini Tie-Downs on vehicles equipped with a Tonneau Cover. Damage to the Tonneau Cover may occur and the Tonneau Cover will not latch properly!**

(a) Remove (DO NOT DISCARD) the end caps from the side rails (Fig. 1-1).

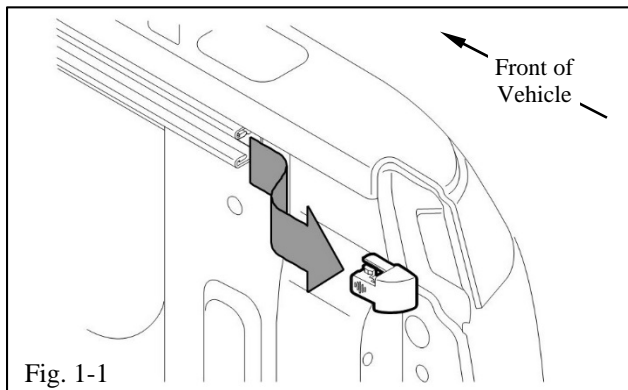

(b) Push the tie-down loop so that the locking plate is equal with the guide surface (Fig. 1-2).

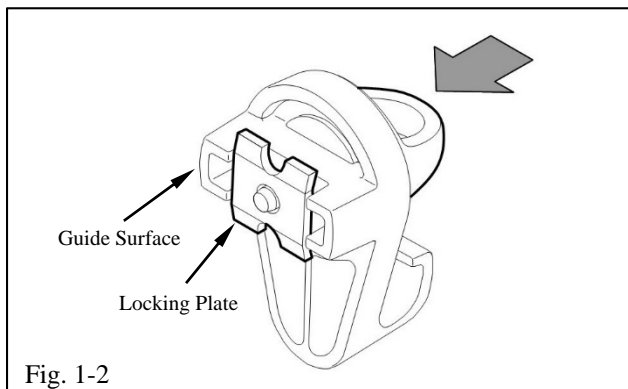

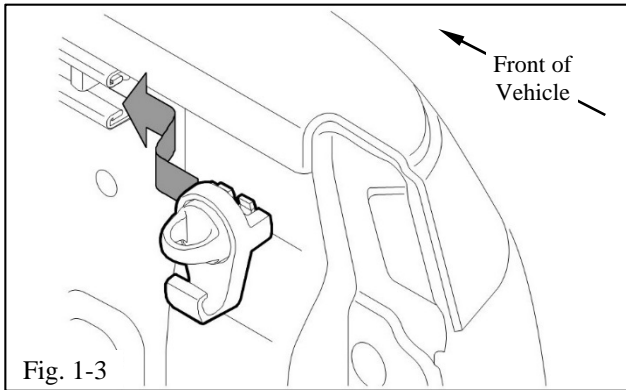

- (c) With the tie-down loop depressed, slide the tie-down into the rails with the hook facing down. The tie-down must be angled to maneuver around the bed post and into the rail. Release the tie-down loop when the locking plate enters the rail (Fig. 1-3).

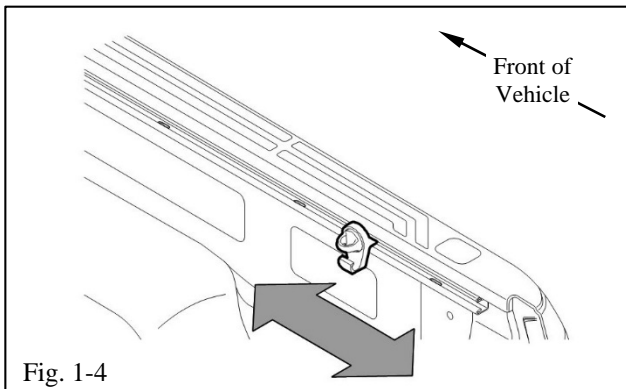

- (d) Slide the tie-down to the nearest detent position and snap it into place. To move it to another detent position, depress the tie-down loop and slide it to the next detent (Fig. 1-4).

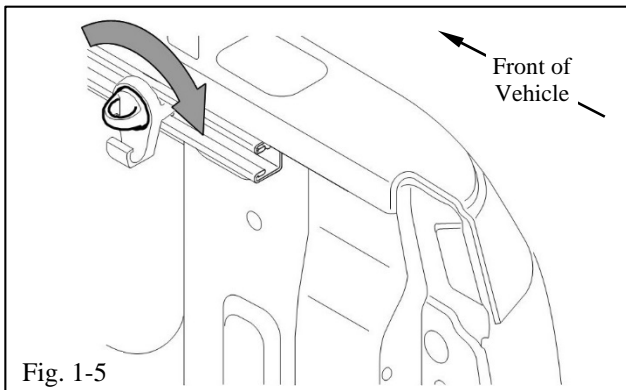

- (e) Rotate the tie-down loop in a clockwise direction until it is tight (Fig. 1-5).
- (f) Repeat Step 1 for the other side.

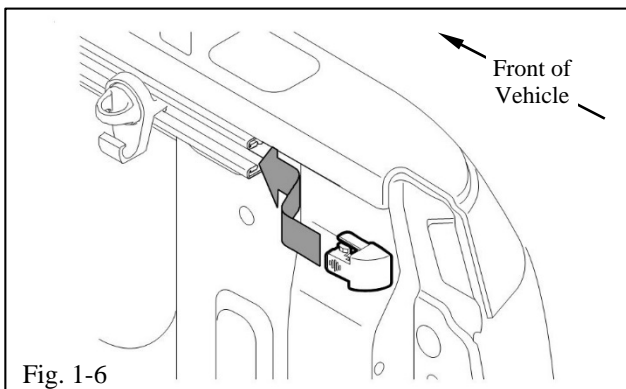

-  (g) Reinstall the end caps (RH & LH) (Fig. 1-6).

Checklist - these points **MUST** be checked to ensure a quality installation.

<u>Check:</u>	<u>Look For:</u>
<p><u>Accessory Function Checks</u></p> <p><input type="checkbox"/> Ensure bed tie-downs are locked into detents</p> <p><input type="checkbox"/></p> <p><input type="checkbox"/></p> <p><input type="checkbox"/></p>	<p>Ensure tie-downs slide into position</p>
<p><u>Vehicle Function Checks</u></p> <p><input type="checkbox"/></p> <p><input type="checkbox"/></p> <p><input type="checkbox"/></p>	
<p><u>Vehicle Appearance Check</u></p> <p><input type="checkbox"/> After accessory installation and removal of protective cover(s), perform a visual inspection.</p>	<p>Ensure no damage (including scuffs and scratches) was caused during the installation process. (For PPO installations, refer to TMS Accessory Quality Shipping Standard.)</p>